

# Budgetline

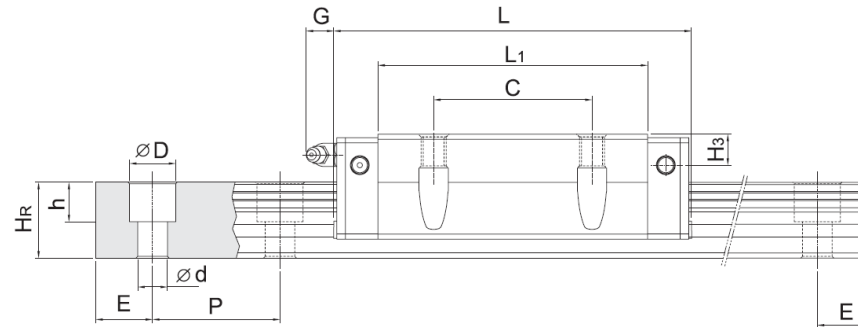

## FLENSWAGEN

Model	Inbouwafmetingen							Maatvoering loopwagen								Maatvoering profielrail						Montage bout rail mm	
	H	H <sub>1</sub>	N	W	B	B <sub>1</sub>	C	L <sub>1</sub>	L	G	M	T	T <sub>1</sub>	H <sub>2</sub>	H <sub>3</sub>	W <sub>R</sub>	H <sub>R</sub>	D	h	d	P		E
H15W	24	4,3	16	47	38	4,5	30	39,4	61,4	5,3	M5	6	8,9	4,5	5,5	15	15	7,5	5,3	4,5	60	20	M4x16
H20W	30	4,6	21,5	63	53	5	40	50,5	75,6	12	M6	8	10	6	7	20	17,5	9,5	8,5	6	60	20	M5x16
H25W	36	5,5	23,5	70	57	6,5	45	58	83	12	M8	8	14	6	9	23	22	11	9	7	60	20	M6x20
H30W	42	6	31	90	72	9	52	70	97,4	12	M8/10	8,5	16	6,5	10,8	28	26	14	12	9	80	20	M8x25

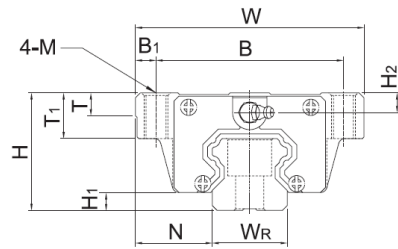
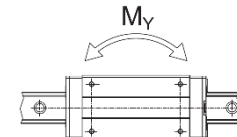
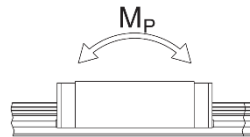
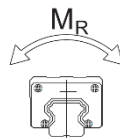

Model	Dynamisch draagvermogen (N)	Statisch draagvermogen (N)	Max. momentbelasting (Nm)		
			MR	MP	MY
H15W	6.385	10.035	75	52	52
H20W	10.275	14.453	170	120	120
H25W	15.143	22.480	292	195	195
H30W	21.060	34.748	487	322	322