

Budgetline

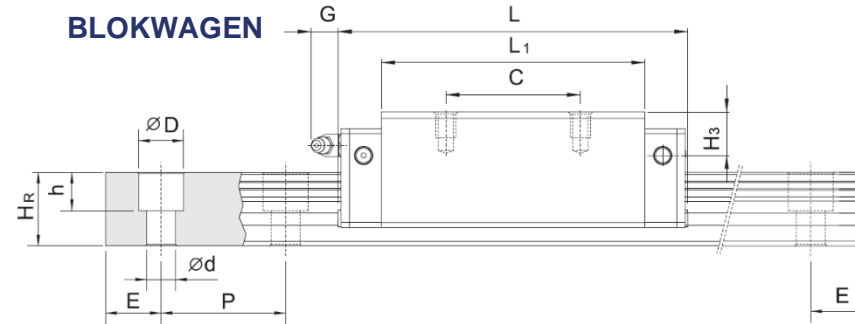

Model	Inbouwafmetingen							Maatvoering loopwagen							Maatvoering profielrail						Montage bout rail mm	
	H	H ₁	N	W	B	B ₁	C	L ₁	L	G	M x ℓ	T	H ₂	H ₃	W _R	H _R	D	h	d	P		E
HGH15	28	4,3	9,5	34	26	4	26	39,4	61,4	5,3	M4x5	6	7,95	7,7	15	15	7,5	5,3	4,5	60	20	M4x16
HGH20	30	4,6	12	44	32	6	36	50,5	75,6	12	M5x6	8	6	6	20	17,5	9,5	8,5	6	60	20	M5x16
HGH25	40	5,5	12,5	48	35	6,5	35	58	83	12	M6x8	8	10	9	23	22	11	9	7	60	20	M6x20
HGH30	45	6	16	60	40	10	40	70	97,4	12	M8x10	8,5	9,5	13,8	28	26	14	12	9	80	20	M8x25

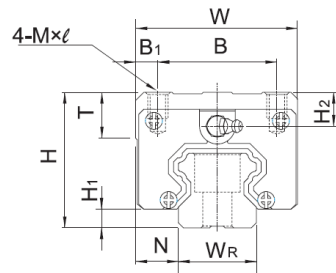
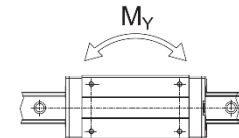
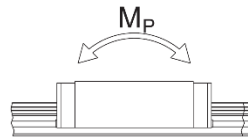
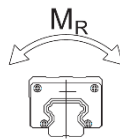

Model	Dynamisch draagvermogen (N)	Statisch draagvermogen (N)	Max. momentbelasting (Nm)		
			MR	MP	MY
HGH15	6.380	10.020	75	52	52
HGH20	10.200	14.800	170	120	120
HGH25	15.140	22.480	292	195	195
HGH30	21.060	34.740	487	322	322