

## Linear Guide Clamp (Medium/Heavy Load Type)

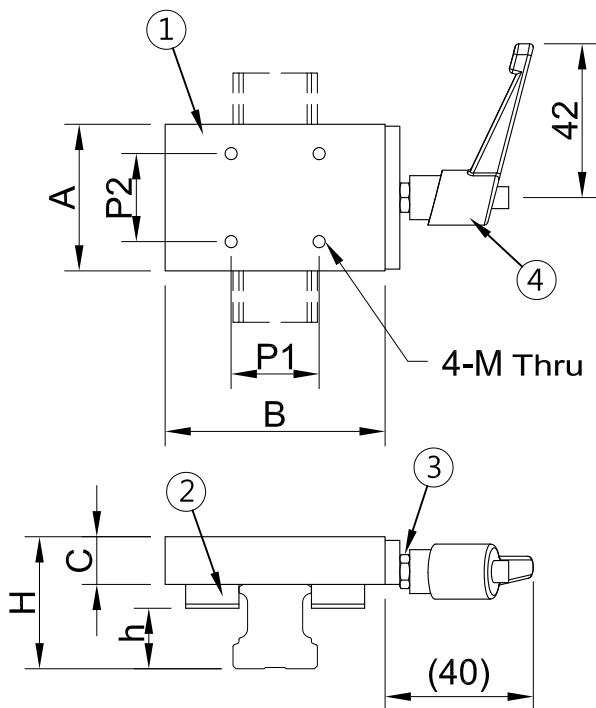

### Clamp Lever Type



### Specifications

Guide	A	B	C	P1	P2	H	h	M
20	40	60	13	25	25	33	13.5	M5

This clamp is for standard linear guides which's width is 20 mm

### Part List

P/N	Part Name	Q'ty	Material	Surface Treatment
1	Housing	1	S45C	Electroless Nickel Plating
2	Block	2		Black Oxidi
3	Hand Thread	1	K.T.	Black
4	Lever	1		

## Step between clamp and block

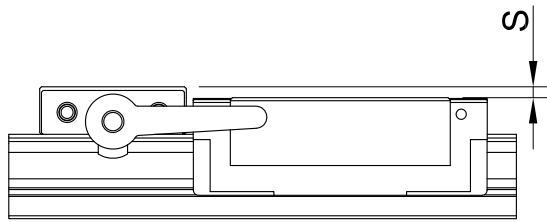

Tightening torque (reference)

- Tightening torque: 2,5 Nm
- Retaining force: 400 N

Opening range: 14-28 mm

Brand / Guide Width	CPC-AR	CPC-HR	THK-SR	THK-HSR
20	5	3	0,5	1

Brand / Guide Width	HIWIN-EGH	HIWIN-HGH	TBI-TRS	TBI-TRH-V
20	0,5	0,5	1,5	0,5

## Instruction

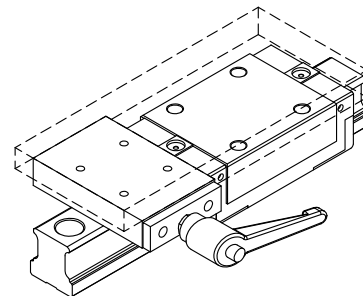
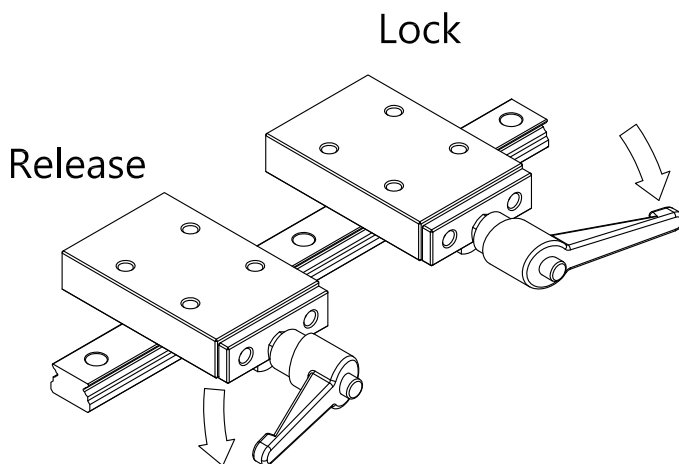

Use a connecting board to combine clamp and block. Then it's possible to locate and lock the block